



Thank you for selecting JELD-WEN® products. Attached are JELD-WEN's recommended installation instructions for Exterior Wood, Steel, and Fiberglass Pre-Hung Doors. Read these instructions thoroughly before beginning. They are designed to work in most existing applications; however, existing conditions may require changes to these instructions. If changes are needed, they are made at the installer's risk. For installations other than indicated in these instructions, contact a building professional.

Newer construction methods have led to an increase in air and water tightness in buildings. This frequently leads to negative air pressure inside the house, which can draw water through very small openings. Our installation method seals the door to the weather barrier (typically building wrap) and uses a sill pan to capture and drain incidental storm water from under the door.

### IMPORTANT INFORMATION & GLOSSARY

Not all exterior door types may be installed into every wall condition in all areas. See our Appropriate Protection document at [www.jeld-wen.com/resources](http://www.jeld-wen.com/resources) for overhang requirements. Consult your local building code official for applicable building codes and regulations. Local building code requirements supersede recommended installation instructions.

**Please Note!** Any exterior door installation where the sill is higher than 35 feet above ground level or into a wall condition not specifically addressed in these instructions must be designed by an architect or structural engineer. Failure to install square, level and plumb and on a flat surface (without twist or warp) could result in denial of warranty claims for operational or performance problems.

**Note to Installer:** Provide a copy of these instructions to the building owner. By installing this product, you acknowledge the terms and conditions of the limited warranty as part of the terms of the sale.

#### GLOSSARY

##### Backer Rod (backing material)

A material (e.g. foam rod), placed into a joint primarily to control the depth of the sealant.

##### Buck

A wood framework attached to the masonry inside a window or a door rough opening.

##### Door System/Pre-Hung Door

A precut and assembled unit consisting of a door slab with the locking or passage hardware hung on hinges in a frame.

##### Hinge Jamb

The side of the jamb on which the hinges of a door are installed.

##### Latch Jamb

The side of the jamb that makes contact with the latch on a door slab.

##### Pre-Hanging Clips

Small, metal or plastic clips that come attached to a door system. These clips help keep a door slab closed and aligned before and during installation.

##### Rough Opening

The framed opening in a wall where a door is to be installed.

##### Security Plate

A metal plate pre-installed into the frame of a pre-hung door. It is designed to provide extra strength and stability to the lockset by allowing the latch of the door to rest inside it while the door is closed.

##### Shiplap

The layering method in which each layer overlaps the layer below it so that water runs down the outside.

##### Sidelight

A fixed, usually rectangular window placed on either side of a door.

##### Sill Pan

A three-sided box made of sheet metal flashing. The door sill sits inside the sill pan in the rough opening. It is designed to catch water that infiltrates into the rough opening and divert it to the outside.

Please allow sufficient time to properly prepare the rough opening, install the entry door, and ensure its proper operation.

Estimated Install Time for New Construction	<input type="checkbox"/> First Time: 4.0 hr.	
	<input type="checkbox"/> Experienced: 2.5 hr.	
	<input type="checkbox"/> Professional: 1.5 hr.	

#### LANDINGS

These instructions cover two sill conditions: the **step-down landing** and the **continuous slab landing**. The installation methods vary slightly between landing types.

##### Step-Down Landing

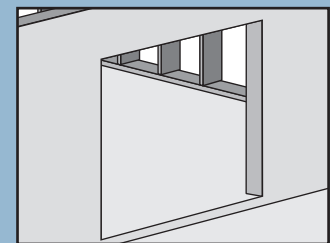

##### Continuous Slab Landing

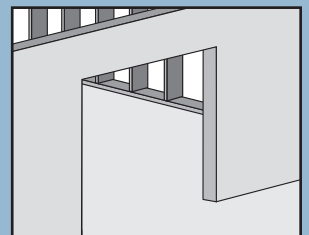

## ROUGH OPENINGS

This installation guide specifically addresses masonry/block wall, sheathed wall and open-stud construction.

### MASONRY/BLOCK WALL CONSTRUCTION

This installation assumes that a building professional has already properly fastened and sealed a framework of studs (often called a buck) to the concrete/masonry wall.

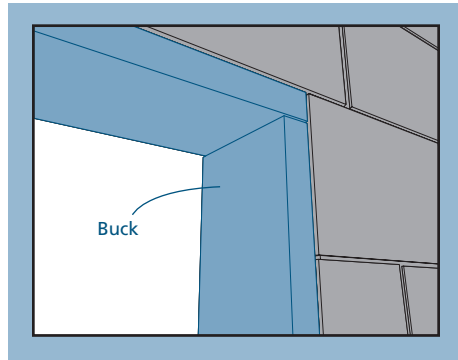

### FULLY SHEATHED WALL CONSTRUCTION

The wall framing is covered by sheathing and the door will be mounted with the exterior trim flush against the sheathing. This installation assumes building wrap is properly installed prior to installation.

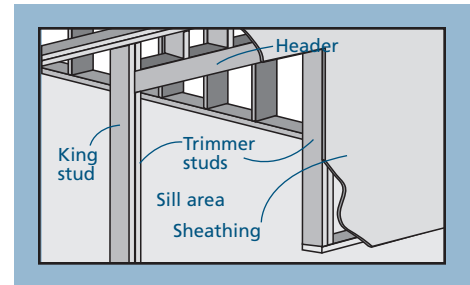

### OPEN-STUD CONSTRUCTION

The wall framing needs to be completely surrounded by backing support (non water-degradable, thin (max. 1/8" thick) sheet material such as plywood or lauan) before installing building wrap and the door. The door will be mounted with the exterior trim flush against the applied backing support.

## SAFETY & HANDLING

### SAFETY

- Read and fully understand ALL manufacturers' instructions before beginning. Failure to follow proper installation and finishing instructions may result in the denial of warranty claims for operational performance problems.
- Do not work alone. Two or more people are required. Use safe lifting techniques.
- Use caution when handling glass. Broken or cracked glass can cause serious injury.
- Wear protective gear (e.g. safety glasses, gloves, ear protection, etc.).
- Operate hand/power tools safely and follow manufacturer's operating instructions.
- Use caution when working at elevated heights.

### MATERIALS & DOOR HANDLING

- Make sure the operating panel is secured prior to installation.
- Heed material manufacturer's handling and application instructions.
- Protect adhesive surfaces from dirt, moisture, direct sunlight and folding over onto themselves.
- Handle in vertical position; do not drag on floor.
- Do not put stress on joints, corners or frames.
- Store door in dry, well-ventilated area in vertical, leaning position to allow air circulation; do not stack horizontally.
- Protect from exposure to direct sunlight during storage.
- Install only into vertical walls and when conditions and sheathing are dry.

**IF INJURY OCCURS, IMMEDIATELY SEEK MEDICAL ATTENTION!**

## NEEDED MATERIALS & TOOLS

### MATERIALS

- Lockset
- 10d galvanized casing or finishing nails (if plan to stain) or #8 x 3" and #10 x 2 1/4" drywall screws (if plan to paint)
- Non-compressible or water degradable shims
- Sealant (polyurethane if painted, 100% silicone if left exposed) and backer rod
- Closed cell polyurethane low expansion foam (Dow Great Stuff™ Window and Door or equivalent)
- Sheet metal flashing or bendable vinyl sheeting for sill pan
- Plastic drain screen with crisscross or woven pattern (sold in 6" widths to protect rain gutters) for step-down landings
- 3/8" staples for step-down landings

For installations into a Buck:

Liquid applied flashing (Protecto Wrap LWM 200 or equivalent)

For installations into a stud-framed wall:

- Protecto Wrap Safseal Systems 5500 spray adhesive/primer (or as recommended by the self-adhesive flashing manufacturer)
- JELD-WEN 6" wide self-adhesive flashing (part #08987) or equivalent (9" if required by local code)
- Drip cap if required because of door location and exposure. Doors with an adequate overhang (see our Appropriate Protection document at [www.jeld-wen.com/learn/resources/care-maintenance](http://www.jeld-wen.com/learn/resources/care-maintenance)) may not need a drip cap.

**Note!** Follow all material manufacturers' instructions for proper use and compatibility.

**NEEDED MATERIALS & TOOLS - CONTINUED**

**TOOLS**

- Cutting shears (sill pan)
- Tape measure
- Utility knife
- Level (4 ft. minimum recommended)
- J-roller
- Caulking gun
- Drill with bits
- Construction stapler
- Hammer
- Phillips screwdriver
- Nail set
- Square

**1**

**REMOVE PACKAGING & INSPECT DOOR**

**REMOVE PACKAGING**

Remove shipping materials such as corner covers, shipping blocks or pads. Remove any staples exposed on the frame, but leave glass protective films.

1. If the door unit includes packaging under the threshold and bottom end of the side jamb, remove it. If the door comes with a security plate on the outside of the frame at the latch, **DO NOT** remove it. Install the door with the security plate attached.

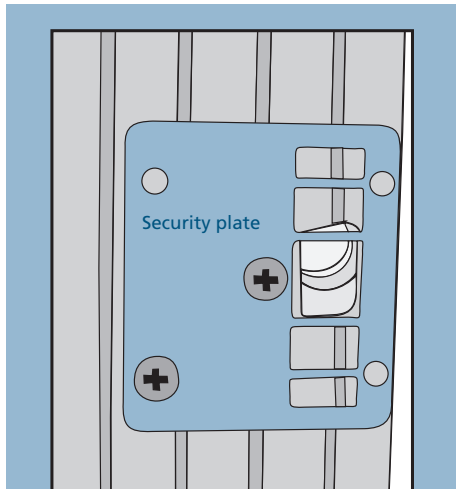

2. If the door is fastened closed with a duplex nail, removable plastic plug, or a shipping strap, remove these along with the packaging and crating.

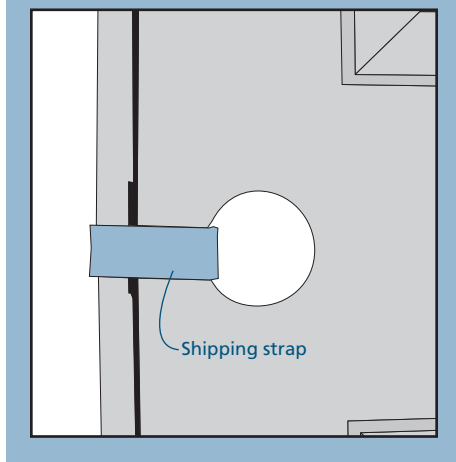

**Note!** If the door has pre-hanging clips, **DO NOT** remove them until instructed to do so. These clips hold the door system aligned and closed during installation.

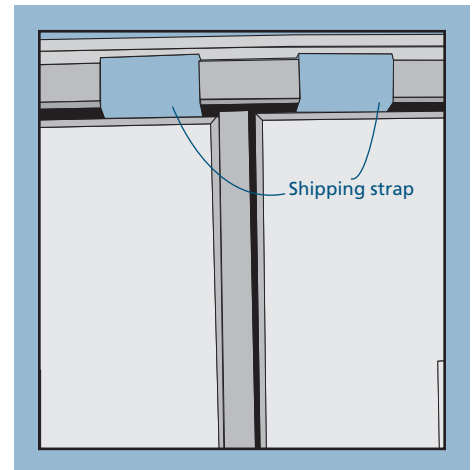

**INSPECT DOOR**

- Cosmetic damage
- Product squareness (diagonal measurements must be within 1/4" difference)
- Correct product (size, color, grid pattern, handing (side the hinges are on), glazing, energy-efficiency requirements, etc.)

If any of the above conditions represent a concern, or if you expect environmental conditions to exceed the door's performance rating, do not install the door. Contact your dealer or distributor for recommendations.

## 2 INSPECT ROUGH OPENING

- Determine prior to installation what the actual finish floor height will be and adjust the rough opening if needed to accommodate a taller unit height. Most doors use a 1 1/4" high threshold which provides adequate clearance in most applications. This ensures that the door does not drag after installation.

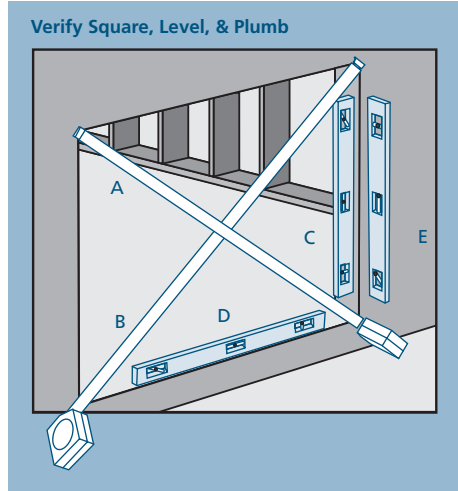

- Verify the width and height of the door are each 1/2" smaller than the rough opening width/height.
- Verify the rough opening is square. The (A) and (B) measurements should be the same. Maximum allowable deviation from square is 1/4".
- Verify the rough opening is level and plumb (C). The maximum allowable deviation is 1/8".
- The rough opening sill must not be crowned or sagged (D).
- The exterior face of the rough opening must be in a single plane (E) with less than 1/8" twist from corner to corner.
- Minimum double studs should be used at all wood framed rough openings.
- The header must be supported by trimmer studs.

## 3 PREPARE SILL PAN

1. Cut a piece of sheet material to the length shown.
2. Lightly crease folding lines 1/2" in from the two short sides and one long side.
3. Measure the distance from the back of the trim to the interior edge of the frame and add 9/16".
4. Take this distance from the back edge and lightly crease a folding line across the sheet material.

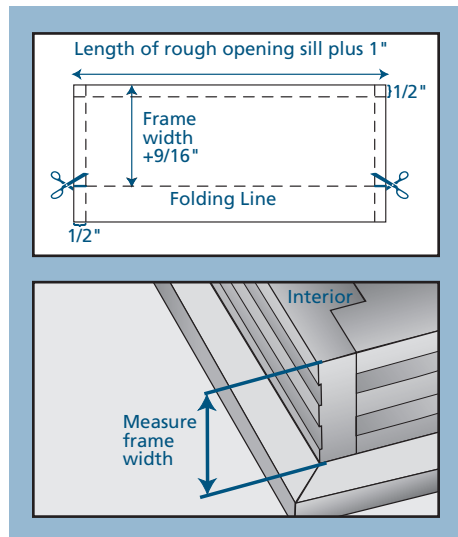

5. For step-down landings, cut 1/2" in at this line on both sides of the sheet material.
6. For continuous slab, cut across the folding line.
7. Fold the three back sides up to make a 3-sided box, and, for step-down landings, fold the front flap down.

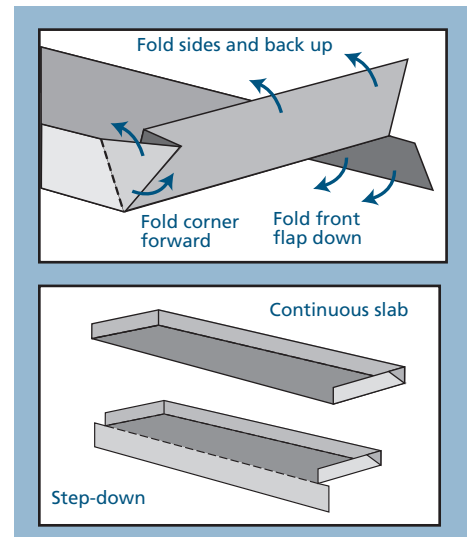

## 4 INSTALL SILL PAN

1. Set the sill pan in the rough opening, aligning the front edge (for continuous slab) or folded down edge (for step down) with the exterior of the rough opening.

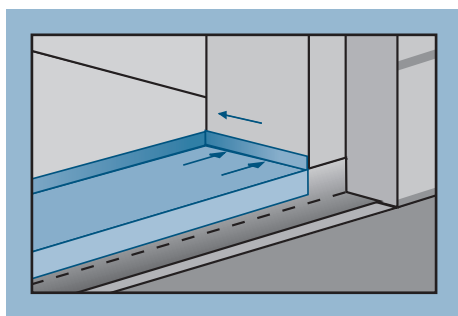

2. Mark a line across the front and back of the sill pan.
3. Apply three 3/8" beads of sealant between the lines.
4. Place the sill pan in the rough opening. Firmly press the sill pan into the sealant with a J-roller.

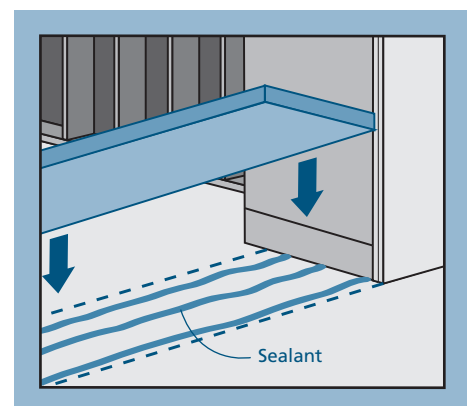

**5** PREPARE BUCK

**Note!** This section applies to installations into a buck only. For installations into a stud-framed wall, begin with section 6, "PREPARE STUD-FRAMED WALL."

1. Seal any joint larger than 1/16" in the buck and between the buck and the concrete/masonry with sealant.
  2. Cover the buck and the surrounding concrete/masonry at the head and jambs and sill with liquid applied flashing as shown.
  3. Apply diamond lath to all flashed surfaces to be covered by stucco.
- END of Buck Instructions, SKIP to section 7, "INSTALL DOOR."**

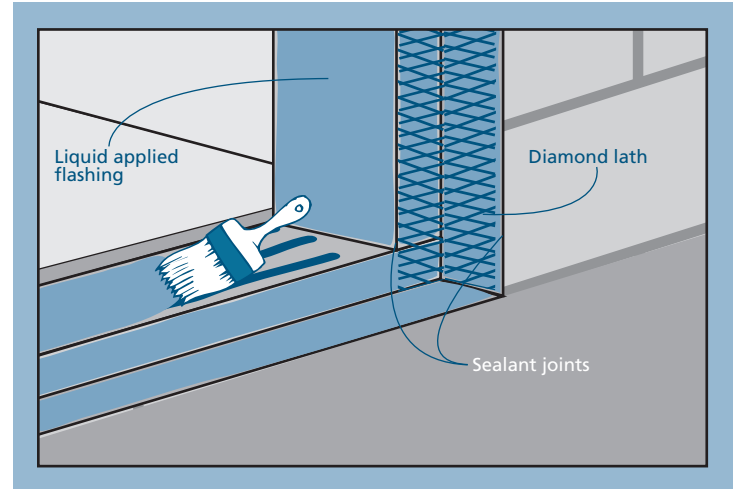

**6** PREPARE STUD - FRAMED WALL

**FOR RETROFIT INSTALLATIONS**

After removing the old door, remove sufficient siding to expose at least 9" of intact building wrap. If damaged, apply new building wrap in a shiplap manner. Verify header and trimmer studs are structurally sound.

**PREPARE BUILDING WRAP**

Verify these steps do not void the building wrap manufacturer's warranty.

1. Trim building wrap flush with the edges of the rough opening.
2. At the head, slit building wrap 6" at 45°. Tape up as shown.
3. Apply spray adhesive/primer to the sill pan and surrounding area. Follow manufacturer's instructions for application methods.
4. Cut a piece of JELD-WEN self-adhesive flashing the length of the sill and apply over the sill pan as shown. The bottom of the sill pan should be completely covered by the self-adhesive flashing. For step down landings, fold flashing down as shown. For continuous slabs, trim flush with rough opening.

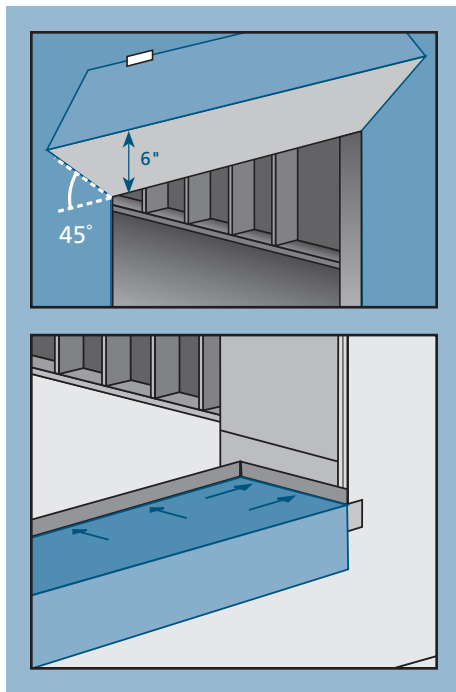

5. Cut two pieces of JELD-WEN self-adhesive flashing 6" wide by the sill pan width + 3" long.
  - a. For continuous slab landings only, cut out the inside corner.
  - b. Adhere the pieces of flashing to the inside corners. Stretch flashing as needed to cover corners and lay flat.
6. Smooth gaps or bubbles beneath self-adhesive flashing with a J-roller (remove and replace if necessary).
7. Seal back corners of sill pan with sealant.
8. For step-down landings only, cut plastic drain screen to length of sill + 2" and staple 1/2" below sill edge. The drain screen provides a path for air to dry any incidental moisture in the rough opening.

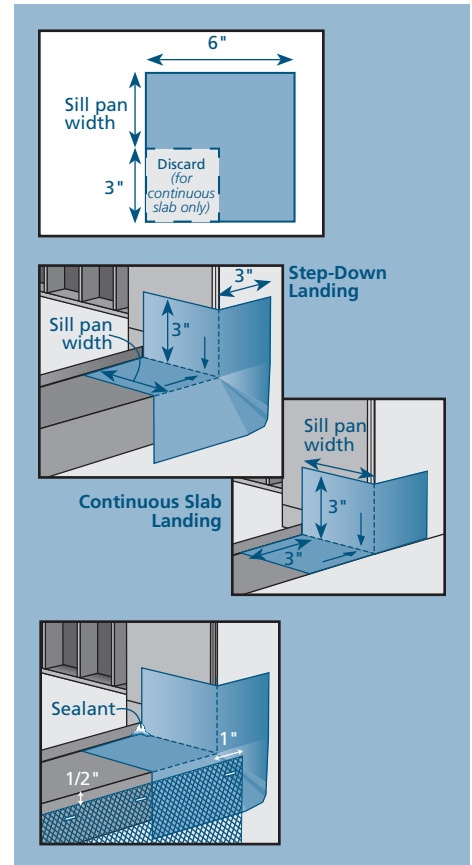

**End of Stud-Framed Wall Instructions, continue with section 7, "INSTALL DOOR."**

**7**

**INSTALL DOOR**

**Warning!** To avoid injury, use at least two people to install. Adequately support the door until fully installed.

**PREPARE DOOR**

1. On the interior side, apply a continuous bead of silicone sealant where the exterior trim meets the door frame as shown. Tool into a fillet shape.

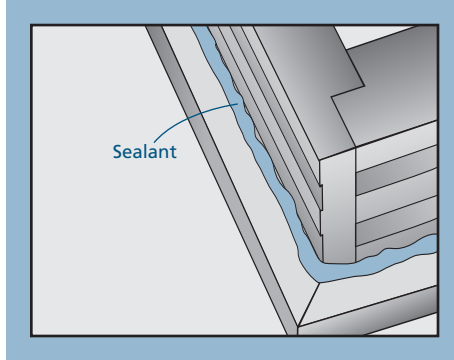

2. Apply a 3/8" continuous bead of sealant across the sill pan back dam and over the flashing joints as shown.

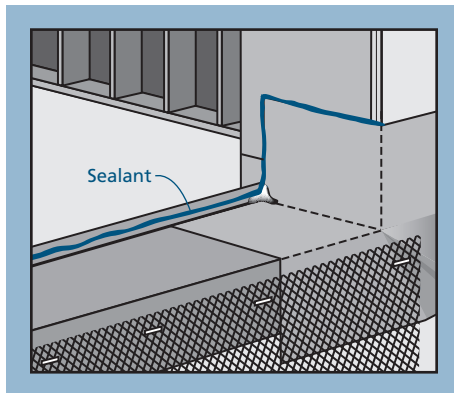

**INSTALL DOOR**

**WARNING!** If installing fasteners through fiberglass components, we recommend pre-drilling holes to keep the fiberglass from splitting.

**Note!** This section covers single door installations. If installing a door unit with a transom or a sidelight(s), there will be additional steps. For double door units, follow the instructions accordingly as they apply to hinge or latch jambs and complete the steps under "ALTERNATE CONFIGURATIONS" later in this section as they apply.

1. Remove any pre-hanging clips that are fastened to the outside of the jamb that will be covered when the unit is placed in the rough opening. Adequately support the slab to keep it from swinging open during installation.
2. Apply a 3/8" bead of sealant to the back of the trim where it will contact the structure. From the outside, tilt the entire pre-hung door into the center of the opening. Make sure the sill contacts the sealant on the sill pan back dam.

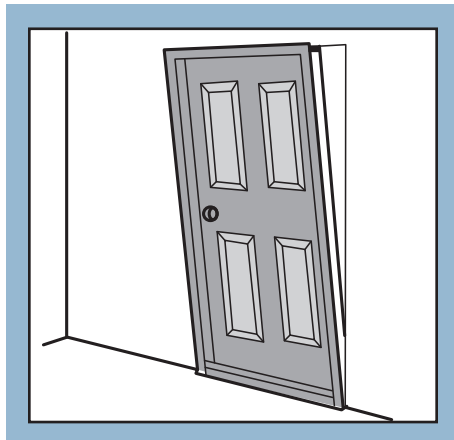

3. Temporarily fasten the hinge jamb by placing one 10d finish nail (or one #8 x 3" drywall screw) horizontally centered in the hinge jamb or brickmould trim 16" from the top and bottom of the door. Do not set nails/screws.
4. From the inside, shim the hinge jamb at each hinge location until the door is square in the opening.
5. From the inside, shim the latch jamb by placing one shim at the strike plate and one across from the top and bottom hinges. Verify the door is square.

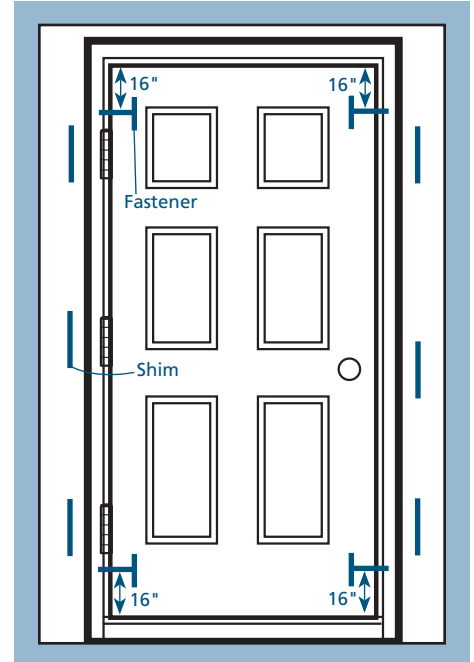

6. Temporarily fasten the latch jamb by placing one 10d finish nail (or one #8 x 3" drywall screw) horizontally centered in the latch jamb 16" from the top and bottom of the door. Do not set nails/screws.
7. Verify the door unit is square, then securely fasten the hinge jamb by setting the two nails or screws installed earlier. Add an additional nail or screw centered between the first two.
8. Remove any remaining pre-hanging clips. Be sure the door opens freely and that the space between the door and the jamb is even on all sides. Adjust if necessary.
9. If adjusting is necessary, loosen or remove the latch jamb fasteners and adjust the latch jamb until there is even contact between the slab and weatherstrip.

**ALTERNATE CONFIGURATIONS**

1. If installing a sidelight, shim and fasten the head on both sides of the joint where the sidelight joins the door jamb. Drive screws next to shims and remove shims after the screws are tight.
2. Fasten double door units or units with sidelight through the top of the door jamb by driving one 10d finish nail (or a #8 x 3" drywall screw) over each slab/sidelight into the door header.

**7**

**INSTALL DOOR - CONTINUED**

- From the inside of doors with sidelights installed on a wood floor, drive two #8 x 3" drywall screws through each door jamb and sidelight into the floor in the locations shown.
- Re-check for smooth door operation and even spacing between the door and jamb. Secure temporary fasteners and secure the latch jamb in place with two more 10d finish nails (or #8 x 3" drywall screws) behind the weatherstrip. Place the nails or screws evenly between the first two already in place and fasten through the shims and into the studs.

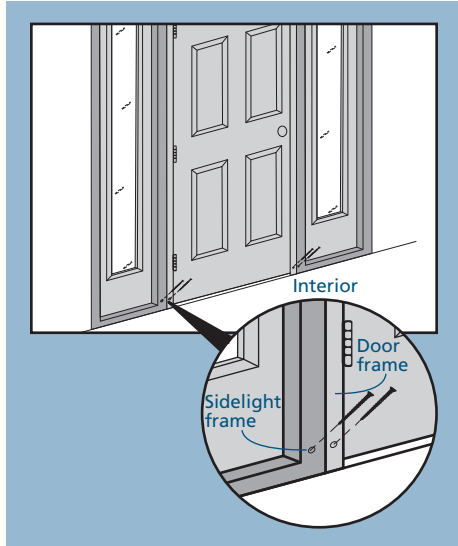

- Make sure the door sweep contacts the threshold evenly with approximately 1/8" compression. If it does not and an adjustable threshold is used, turn the adjustment screws on the threshold clockwise to lower the threshold or counterclockwise to raise it.

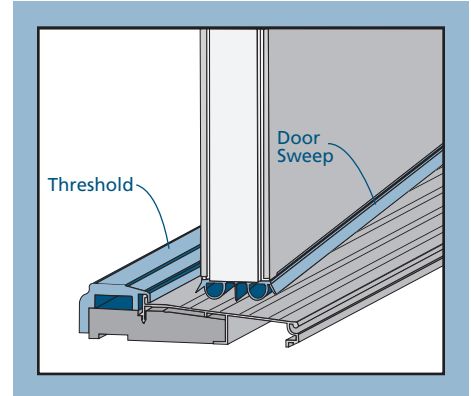

- The foam wedges included with entry doors are used to complete the weatherstrip seal at each bottom corner of the operating door panel(s). Doors will be provided with one of two types of wedges. One has an up-turned L-shaped leg (shown) and the other is a simple wedge. For both types, the thin edge faces the edge of the door as it swings closed. Apply a bead of sealant at the intersection of the jambs, brickmoulds, thresholds and floor as shown.

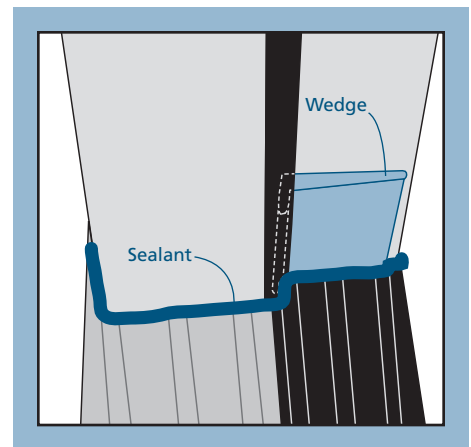

**INSTALL DRIP CAP**

Install drip cap if required.

**FINISH INSTALLATION**

Steps 1 & 2 apply only to single units without sidelights.

- Install two #10 x 2 1/4" wood screws in the top hinge through the two holes closest to the weatherstrip, driving them through the hinge jamb and into the studs. Remove the screws supplied with the hinges to insert these longer screws.
- In the same manner, install one #10 x 2 1/4" wood screw into the remaining hinges.
- Some double door units may require installing lock bolts at the top and bottom of the inactive panel. Follow the instructions that come with the product if possible. Otherwise, locate the center point of each lock bolt, drill 3/8" bolt holes and install keeper plates.

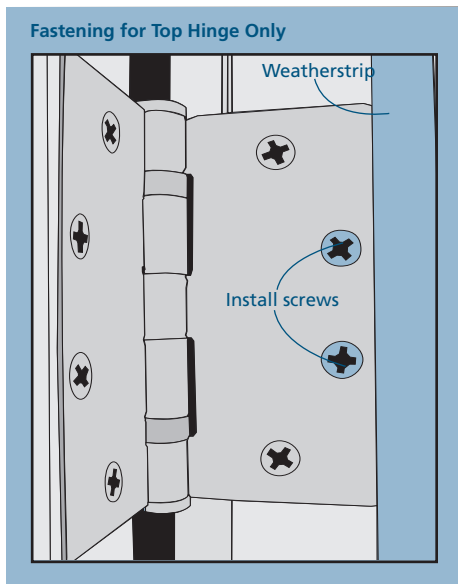

- Apply sealant around the outside of the door unit between the siding and brickmould and between the brickmould and the jamb. Also apply sealant along the front side of the threshold (leave 1" gaps every 12" to allow for water drainage) and between the jamb sides and the threshold as shown.

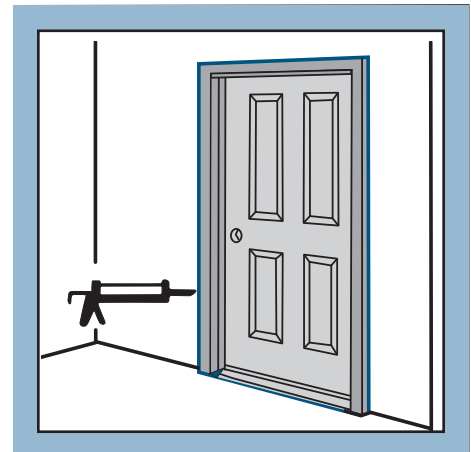

- Create a continuous air seal on the interior between the rough opening and the door frame with low expansion foam.
- Ensure sealant on back dam of the sill pan fully seals to the inside face of the sill. Apply more sealant as necessary.
- On the exterior of step down landings, install support trim underneath the sill where it extends past the landing. Position trim snugly against the bottom of the sill toe/nose.

**7** INSTALL DOOR - CONTINUED

**FIRE DOOR INSTALLATION**

Please see our separate document for additional requirements for installing fire-rated doors at [www.jeld-wen.com/resources](http://www.jeld-wen.com/resources). Automatically closing hinges are required on fire doors, so the appropriate adjustment procedure is as follows:

Adjust spring tension:

1. Close door.
2. Insert the provided hex wrench so that it can be rotated clockwise.
3. Rotate hex wrench 1/4 turn and insert tension pin loosely into tension hole.

4. Remove hex wrench and try closing force.
5. Repeat steps until closing force is adequate but do not rotate past 3 holes on 180° openings or 4 holes on 90° openings.

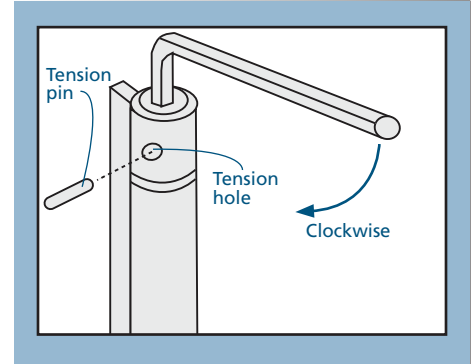

**8** COMPLETE INSTALLATION

1. Fill any nail/screw holes and sand smooth.
2. Finish all six sides of the door slab as well as the frame.
3. Install exterior wall surface within seven days of installation.
4. Install lockset hardware per supplied instructions.
5. Remove protective film (if applicable) on glass within one year.
6. Protect recently installed units from damage from plaster, paint, etc. by covering the unit with plastic.
7. Install any interior trim as desired.

Please visit [jeld-wen.com/resources](http://jeld-wen.com/resources) for finishing instructions, warranty and care and maintenance information.

Thank you for choosing

